

Activity board

As an option the CANDIP can be used with the LAWICEL Activity board ACB1, this board make fast prototyping possible and also perfect for education and testing. The Activity board has an IC socket/carrier for the CANDIP, power supply which work both for AC as well as for DC input and has no direct pin for plus and minus (since it has an on board rectifier), the board also provides ISP (In System Progammable) connector according to Atmel/Kanda IDC10 connector, so the STK200/300 programmer could be used to program the CANDIP. Further more there are some push buttons and LED's for easy testing and simulating inputs and outputs; there is also a 3bit jumper, which could be used as node selection (possibility to use up to eight activity boards) and some jumpers to select CAN termination and to enable power on the CAN bus according to CiA (CAN in Automation) draft standard DS102. Finally there is a large prototyping with 0.1" pitch.

Jumper J3 selects if you like to hook up the on board push buttons or leds for simulation, each port pin PB0 to PB3 can be set to either output or input or left open to be used for your own hardware. When used as inputs you need to configure the AVR to use the programmable pullups for the corresponding I/O pin. Jumper J4 can only be used to simulate different inputs and the corresponding programmable pullup for that pin has to be set if they are used as inputs.

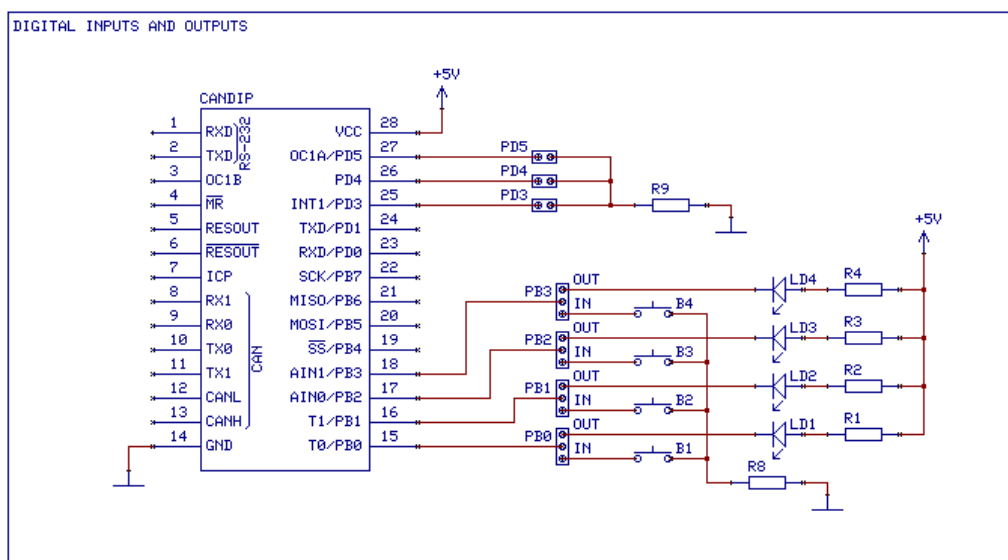

Figure 2 showing the digital inputs/outputs of the Activity board.

Jumper J1 selects a termination of 120ohm for the CAN bus and jumper J2 enables the +V voltage on pin 9 in the CAN connector, so the board could be supplied via the CAN bus or supply other nodes via the CAN bus, that way it is possible to only have one power supply to support all nodes in a network.

Connector K4 is the ISP programming interface and has the same configuration as the STK200/300 programmer from Atmel or the AVRISP from Kanda etc. A red LED is indicating that the programmer is in active operation (i.e. reading, erasing or programming).

For more information and “latest news” see online at <http://www.lawicel.com/candip/>